



3D HUBS

Producing Metal Parts

CNC vs. Additive Manufacturing

www.3dhubs.com

Introduction

This Kit discusses how to select the right manufacturing process for metal parts by comparing CNC and Additive Manufacturing (AM) technologies. A step-by-step summary is included at the end.

Contents

Executive Summary	3
CNC	5
Additive Manufacturing (AM)	10
Powder Bed Fusion	10
Binder Jetting	14
Metal Technologies Compared	18
Powder Bed Fusion vs. Binder Jetting	18
CNC vs. Additive Manufacturing	19
How-to get started	20
3D Hubs Resources	21

Executive Summary

When choosing between CNC and Additive Manufacturing (AM) technologies for producing metal parts, there's a few simple guidelines that can be applied to the decision making process. As a rule of thumb, all parts that can be machined with limited effort should generally be CNC machined. It usually only makes sense to apply Additive Manufacturing in cases where traditional methods are not able to produce the part, e.g. for highly complex geometries.

If high quantities of the part are needed, more traditional methods, such as Investment and Die Casting are generally the most price competitive options.

The following diagram serves as a highly simplified reference for decision making.

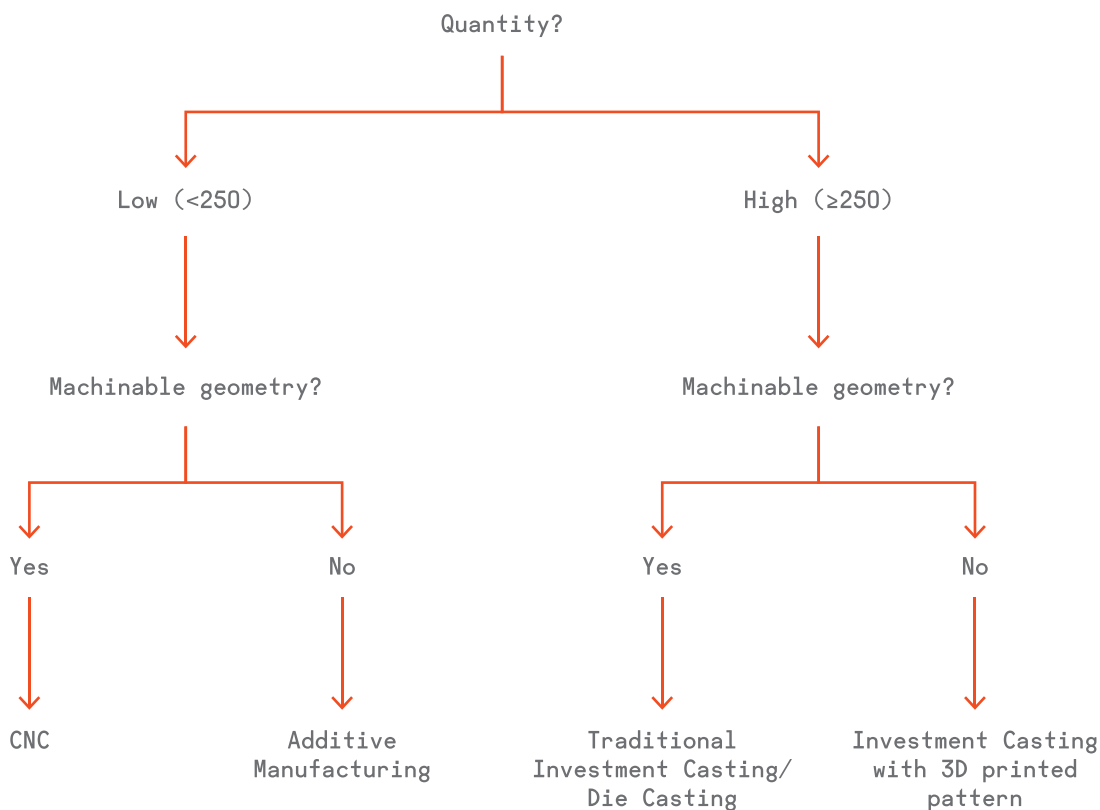

The table below compares specifications of CNC against the two most common AM technologies for producing metal parts.

	CNC	Powder Bed Fusion	Binder Jetting
Tolerance	+/- .001" - .005"	+/- .004"	+/- .008"
Minimum wall thickness	0.030"	0.016"	0.080"
Maximum part size	Milling: 78" x 32" x 40" Lathe: 20" diameter	9" x 6" x 6"	15" x 14" x 29"
Strengths / Weaknesses	+ Low Cost + Highly accurate + Great mechanical properties + Large parts - No complex geometries	+ Highly accurate + Great mechanical properties + Complex geometries - High cost - Small parts only	+ Low cost + Large parts + Complex geometries ~ Good mechanical properties - Limited accuracy

CNC

Computer Numerical Controlled (CNC) machining is a high speed, high precision subtractive manufacturing technology. The process typically begins with a solid block of material (blank) and, using a variety of sharp rotating tools or cutters, removes material to achieve the required final shape. CNC machines come in essentially two standard types: milling machines and lathes (for circular geometries).



CNC Milling machine

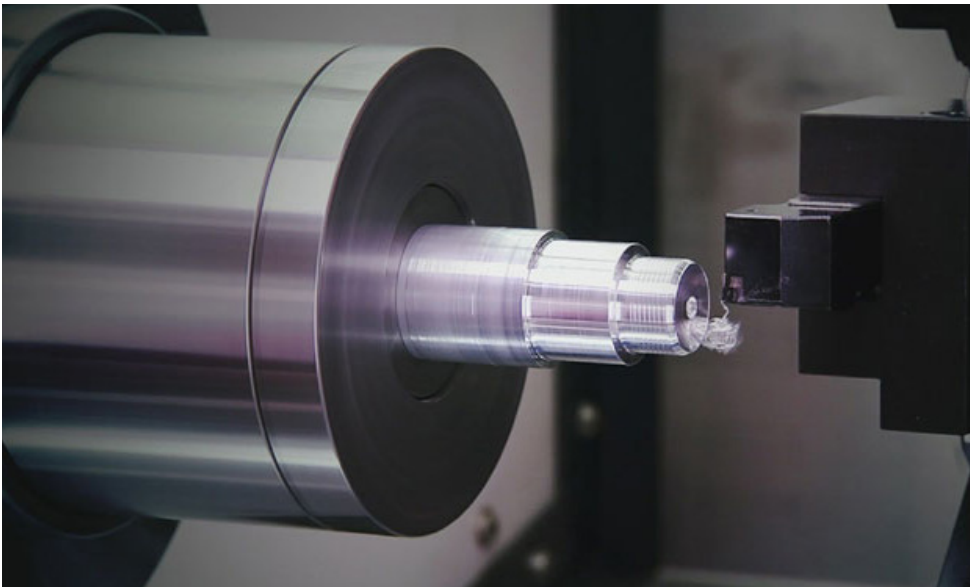

CNC Lathe machine

CNC machining is one of the most popular methods for both one-off and low-volume production of metal parts, offering excellent repeatability and high precision at a very competitive price. There are a number of limitations that must be considered when designing parts for CNC machining, including tool access and clearances, hold or mount points, as well as the inability to machine square corners due to tool geometry.

For more complex parts therefore, CNC machining becomes less efficient, as the machine setup and cutting time increase. Also, at higher volumes, e.g. runs over 250 parts, alternative methods of production tend to become more price competitive.

Specifications

Tolerance	+/- .005" (0.125mm)
Finish	As machined
Minimum wall thickness	0.030" (~0.75mm)
Maximum part size - Milling	78" (200cm) x 32" (80cm) x 40" (100cm)
Maximum part size - Lathe	20" (50cm) diameter

Table: Standard specifications for [CNC machining on 3D Hubs](#).

Tighter tolerances, up to +/- .001" (0.025mm), are available when specifying the project. Secondary surface treatments, such as bead blasting, anodizing, and powder coating can all be added upon request.

Materials

Aluminum 6061	High machinability, good strength to weight ratio
Stainless steel 304	High durability, good strength and fatigue properties
Brass C360000	Good machinability, ideal for moving parts

Table: CNC materials available at 3D Hubs

When choosing a material for your design it is useful to consider the following:

Material hardness: softer metals (e.g. aluminum or brass) require less machine time and thus have lower machining cost than harder materials (e.g. stainless steel). Generally, aluminum will machine 2 times faster than stainless steel.

Blank size: the material blank is the size of the solid material that is used to create the part. As a rule of thumb, the blank dimensions are a minimum of 0.125" (3mm) larger than the part. Using a blank that is of standard stock sizing, e.g. 1" x 1" x 1" (thus a maximum part size of 0.875" x 0.875" x 0.875") can significantly reduce the cost of a part.

Finishes

As Machined	~125 RA μin (3.2 RA μm). Minor tool marks will be visible on the part. Surface finish requirements can be increased to 63, 32, or 16 RA μin .
Bead Blast	Matte finish with light texture is achieved by blowing small glass beads against the part.
Anodizing Type II	Corrosion resistant finish. A variety of different colors can be applied when anodizing.
Anodizing Type III	Adds a wear resistant layer on top of the corrosion resistance of Type II.
Powder Coat	Strong, wear and corrosion resistant finish, that is more durable than the methods mentioned above. Powder coat finishing are available in large range of colors.

Table: finishing options for CNC machining parts. Other finishing options, like chrome plating or knurling, are available upon request.

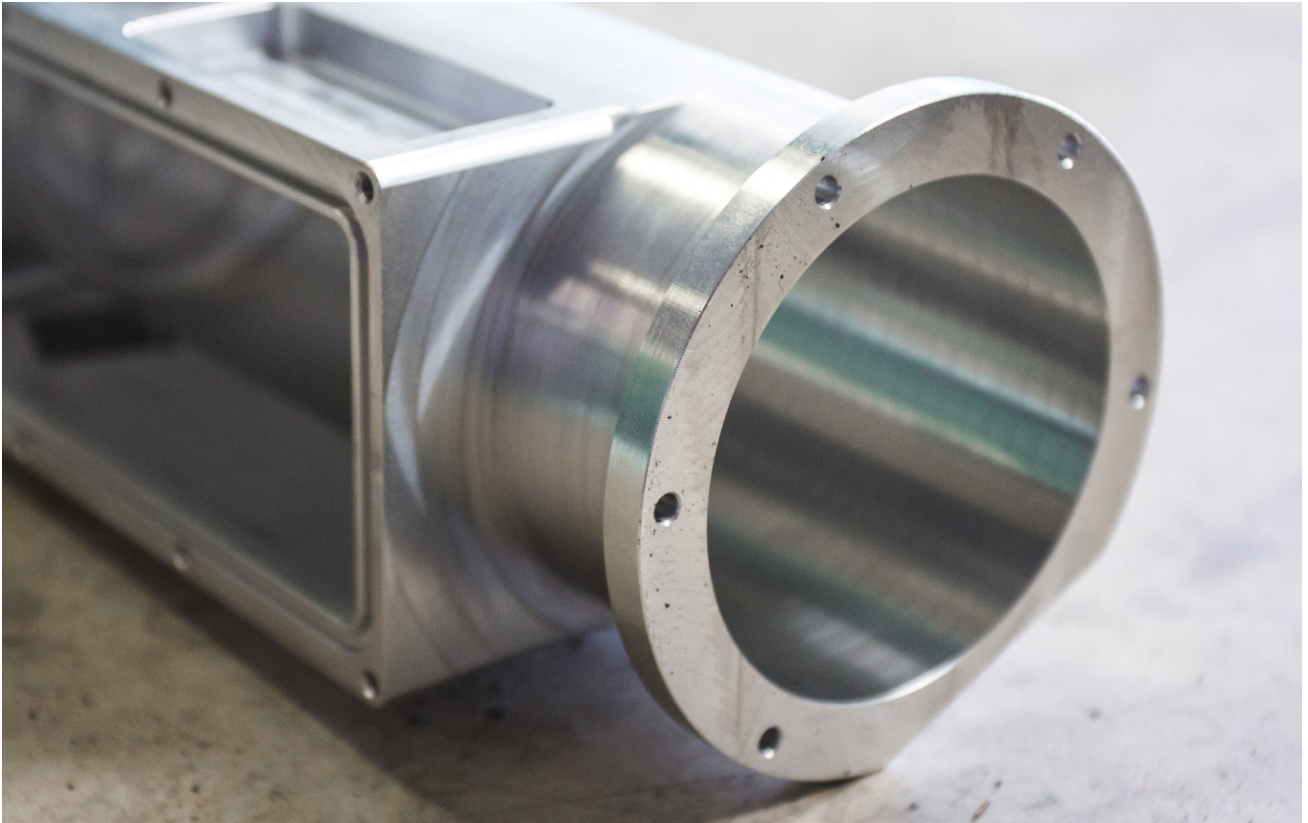

CNC aluminum part with "as machined" finish

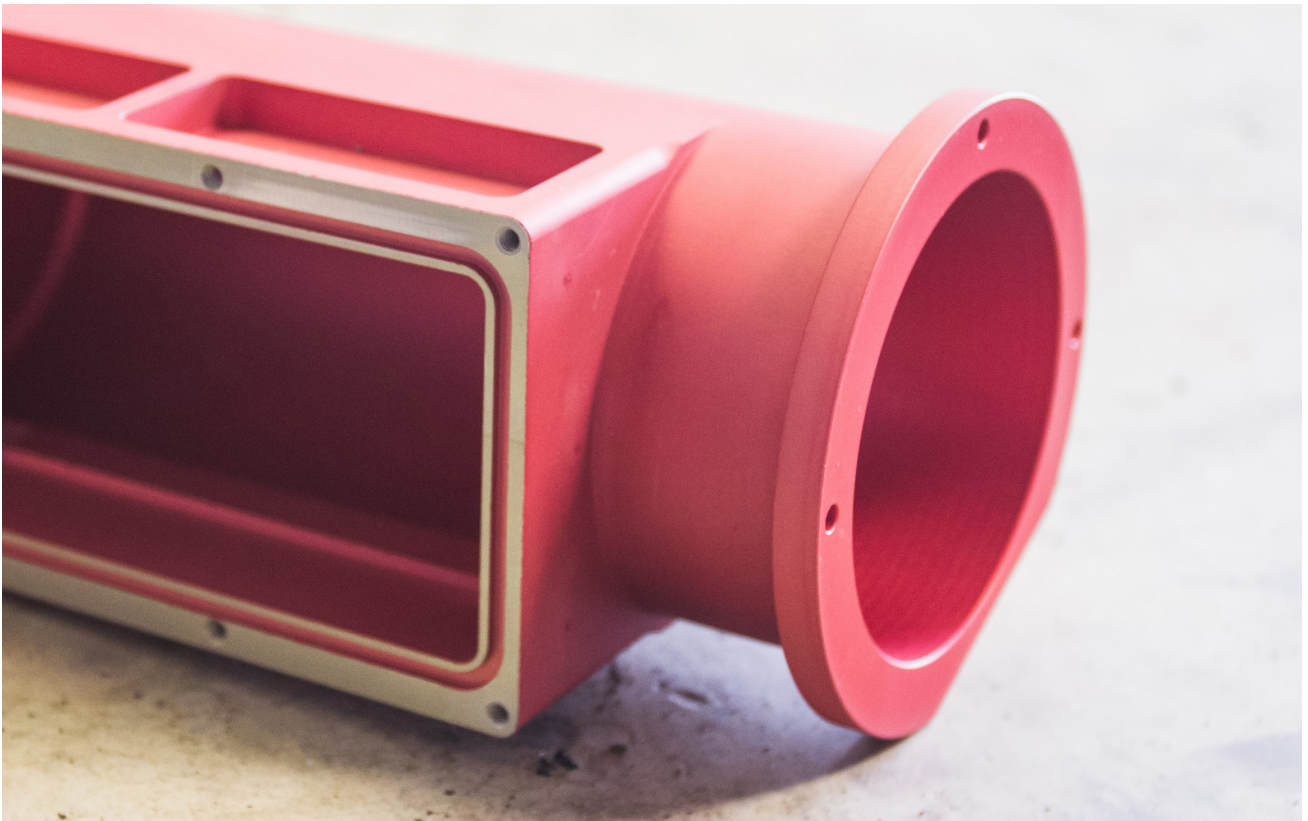

The same CNC aluminum part after red Anodized Type II finish. Chrome plating is added to the visible part, not in red.



A CNC steel part made using a lathe

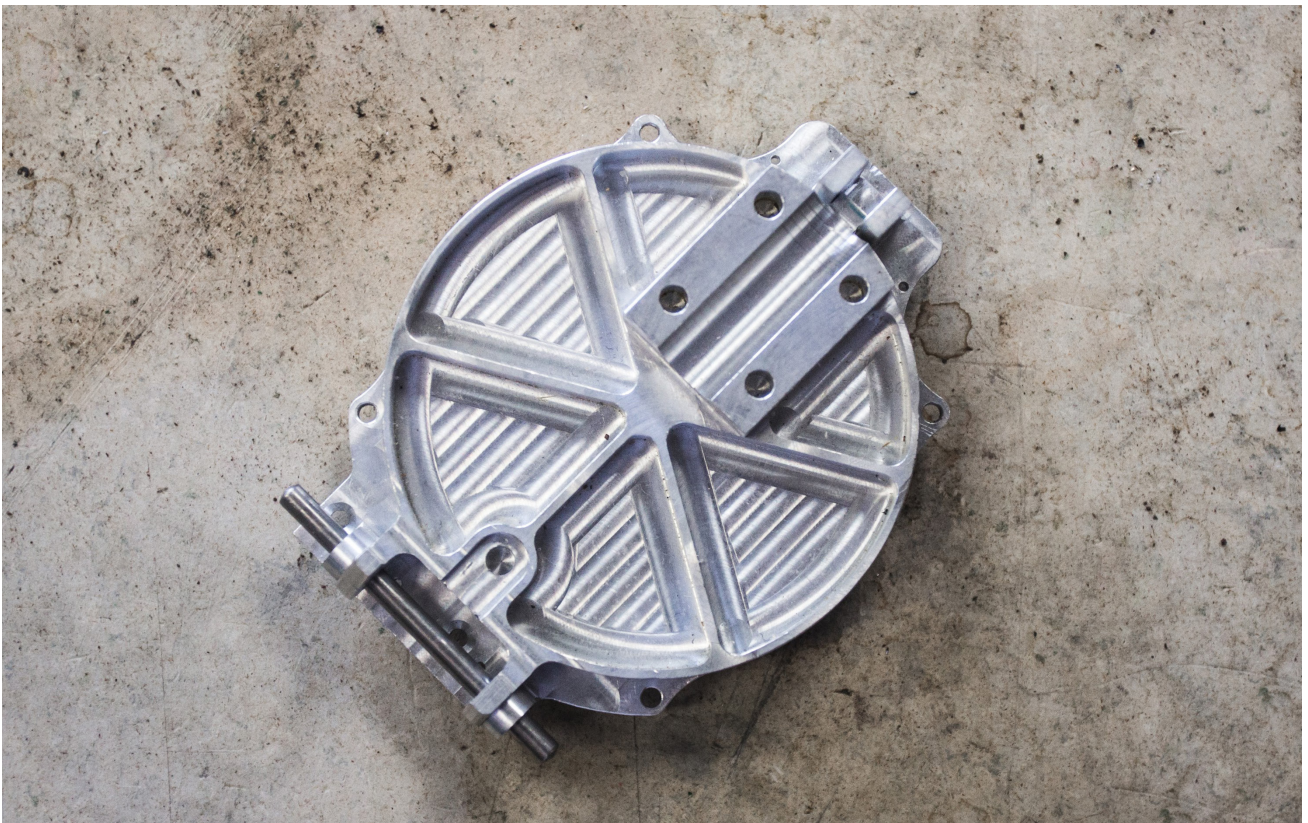

Assembled CNC aluminum part with "As Machined" finish

Additive Manufacturing (AM)

Producing metal part using [Additive Manufacturing \(AM\)](#) can be achieved using 2 fundamentally different technologies: Powder Bed Fusion and Binder Jetting. As their specifications and applications differ, both will be treated separately. More niche specific metal AM technologies such as Direct Energy Deposition (DED) are outside the scope of this document.

Powder Bed Fusion

[Powder Bed Fusion technologies](#) use a thermal source to induce fusion between powder particles, one layer at a time, in order to build up a solid part. Powder Bed Fusion metal AM machines can further be divided into 3 different types:

Direct Metal Laser Sintering (DMLS): fuses together metal powder on a molecular level, using a laser. DMLS only works with metal alloys.

Selective Laser Melting (SLM): laser achieves a full melt of the powder. Resulting parts have a single melting temperature. Because of this, SLM is used to produce parts from single element metals, such as Titanium.

Electron Beam Melting (EBM): uses a high energy beam (electrons) rather than a laser (photons) to induce fusion between metal powder particles. Compared to SLM and DMLS, EBM has a generally superior build rate because of its higher energy density. Minimum feature size, layer thickness and surface finish are typically larger.

For simplicity reasons, in this document, all Powder Bed Fusion technologies are treated equally.

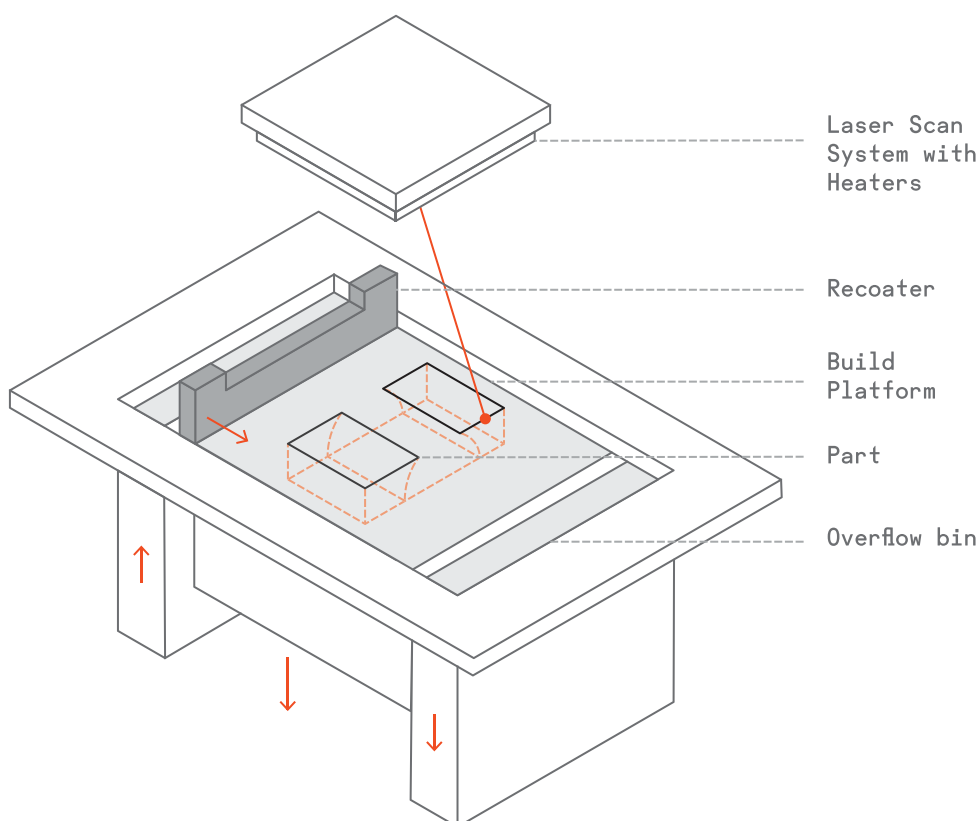

Like CNC machining, Powder Bed Fusion technologies are ‘mould-less’, so initial setup cost per part are limited. Unlike CNC, no ‘blank’ is needed to subtract material from (hence the name “Additive”), allowing Powder Bed Fusion to print highly complex geometries that traditional manufacturing techniques are unable to produce.

Applications include topographical optimizations to achieve weight reduction (e.g. Aerospace) or custom organic shapes (e.g. Medical and dental applications). The main limitations for metal Powder Bed Fusion are cost and build size.

Specifications

Tolerance	+/- .004” (0.102mm)
Positive features	+/- .001” - .006” (0.025mm - 0.152mm)
Negative features	+/- .004” - .006” (0.102mm - 0.152mm)
Minimum wall thickness	~0.016” (0.4mm)
Maximum part size	~ 9” (23cm) x 6” (15cm) x 6” (15cm)

Table: Standard specifications for metal Powder Bed Fusion on 3D Hubs are as follows.

Values are typical and the exact tolerances are design dependent. It is important to note that maximum part sizes are significantly smaller with Powder Bed Fusion than with alternative technologies.

Materials

Aluminum	High strength to weight ratio
Stainless steel	High durability, good strength and fatigue
Titanium	Extreme strength to weight ratio, Higher cost
Inconel	High temperature and corrosion resistant

Table: AM Powder Bed Fusion metals available at 3D Hubs

The amount of material used is the main cost driver for Powder Bed Fusion. It is advised that parts are specifically designed for Powder Bed Fusion in order to be cost effective.

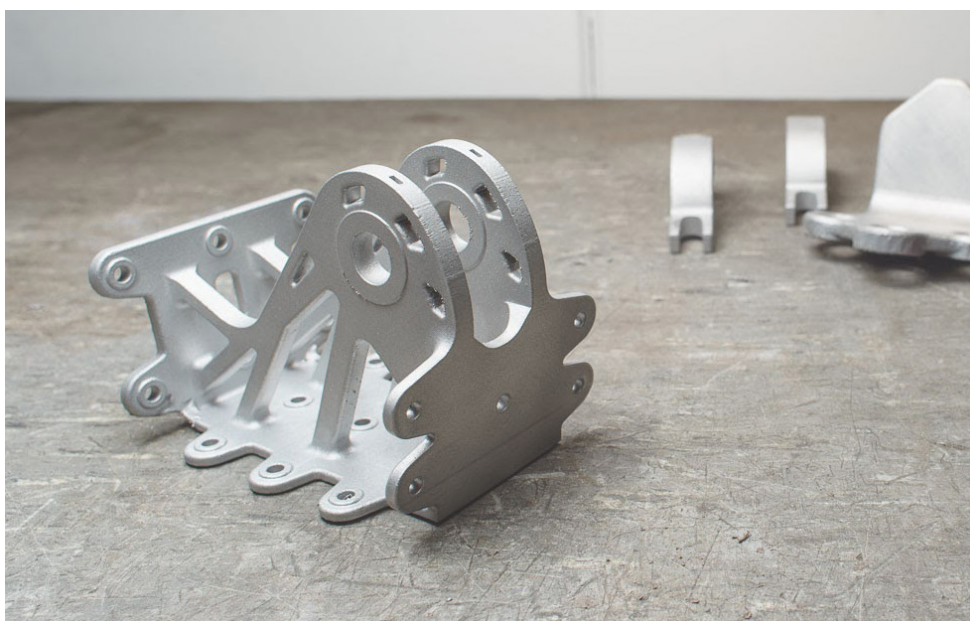

A complex Aluminum bracket produced via Powder Bed Fusion with a design optimized for weight reduction and minimal cost.

Finishes

As printed	Removal of support material from a printed part and smoothing out surface finish. $\sim 350 \text{ Ra } \mu\text{in}$ ($8.75 \text{ Ra } \mu\text{m}$).
Media blast	Matte finish with light texture is achieved by blowing small beads (bead material depends on part material) against the part. After media blasting the surface finish is improved to $63 \text{ Ra } \mu\text{in}$ ($1.6 \text{ Ra } \mu\text{m}$).
Micro-polishing	Used for demanding surface finish requirements such as blades on gas turbine engines to improve resistance to corrosion and reduce friction. The surface finish can be improved to $<32 \text{ Ra } \mu\text{in}$ ($<0.8 \text{ Ra } \mu\text{m}$).
Metal plating	Plating of metals is desirable to augment the characteristics of the part. Improvements could include corrosion and heat resistance, increased strength, hardness, conduction or aesthetics.

Table: finishing options for CNC machining parts. Other finishing options, like chrome plating or knurling, are available upon request.



Powder removal after printing. Build plate contains 20 custom parts in steel.

Binder Jetting

Binder Jetting is the process of printing a binding agent onto a powder bed to form a part one layer at a time. Unlike Powder Bed Fusion, which uses a laser to sinter powder, binder jetting moves a print head over the powder surface depositing droplets that bind (glue) the powder particles together to produce the final part. Once a layer has been printed, the powder bed is lowered and a new layer of powder is spread over the recently printed layer. This process is repeated until a solid part is generated.

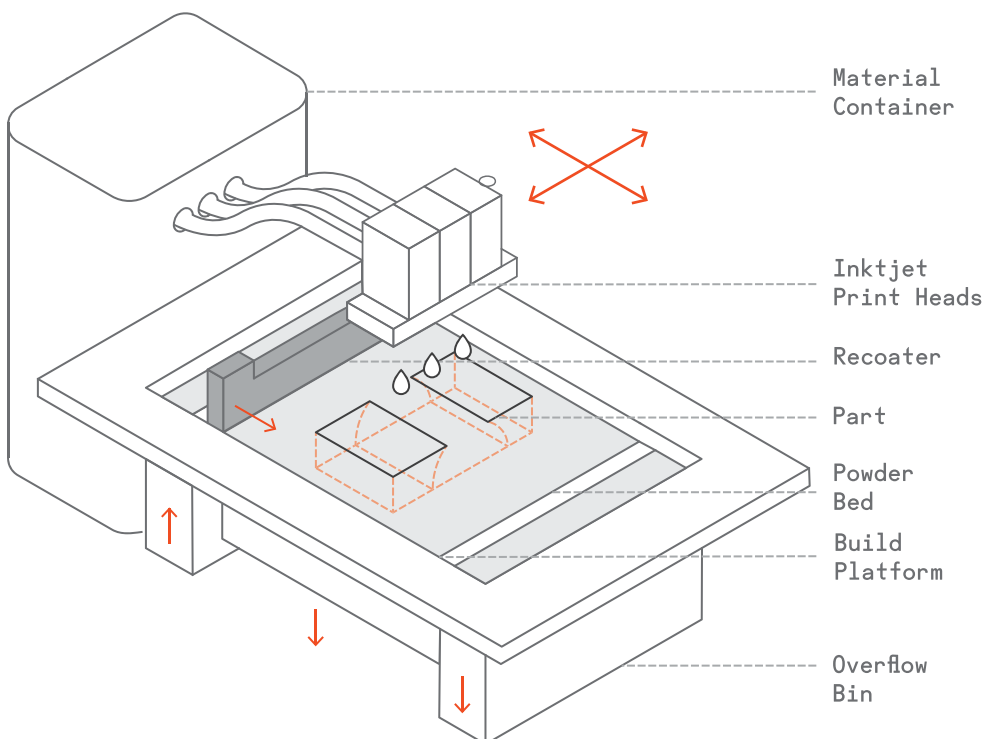

Binder Jetting is of significantly lower cost (by several orders of magnitude) than Powder Bed Fusion and allows for very large parts (e.g. die casts) to be printed.

Because Binder Jetting utilizes a polymer binding agent to bind the metal powder, functional metal parts can only be produced via secondary processes. Without these, metal Binder Jetting parts have poor mechanical properties.

Once parts are removed from the powder bed, they are placed in a furnace where the binder is burnt out, leaving voids throughout the part. Bronze is then used to infiltrate the voids within the print resulting in a high density part with improved mechanical properties. Parts can also be produced without infiltration by sintering in a furnace to a high density. Even with these processes, Binder Jetted parts generally have lesser mechanical properties than parts created through Powder Bed Fusion.

Thermal shrinkage occurs during infiltration or sintering, typically 0.8 - 2%, which is unpredictable and non-uniform. As a general rule, it is advised to scale up designs by ~1.5% to account for shrinkage. Because of this, Binder Jetting is the least dimensional accurate technology presented in this document.

Binder Jetted parts tend to have a matte gray-to-bronze finish with external surfaces smoothed via tumbling.



*Binder Jetted metal parts. Before secondary processes (left) and after infiltration and tumbling (right). Image courtesy of ExOne.

Specifications

Tolerance	0.008" (0.2mm)
Minimum wall thickness	0.08" (2mm)
Maximum part size	15" (38cm) x 14"(36cm) x 29" (74cm)

Table: Standard specifications for metal Binder Jetting on 3D Hubs are as follows:

Materials

Stainless steel-bronze matrix (infiltrated)	Excellent mechanical properties, can be machined
Stainless steel (sintered)	Corrosion resistance, excellent mechanical properties
Inconel alloy (sintered)	Good temperature resistance, excellent mechanical properties, high chemical resistance
Cobalt / chrome (sintered)	Good wear resistance, high melting point
Tungsten carbide (sintered)	Very hard. Used for the production of cutting tools

Finishes

Binder Jetted metal parts that make use of infiltration or sintering are able to be post processed using the same techniques as described for Powder Bed Fusion; media blasting, micro-polishing, and metal plating.

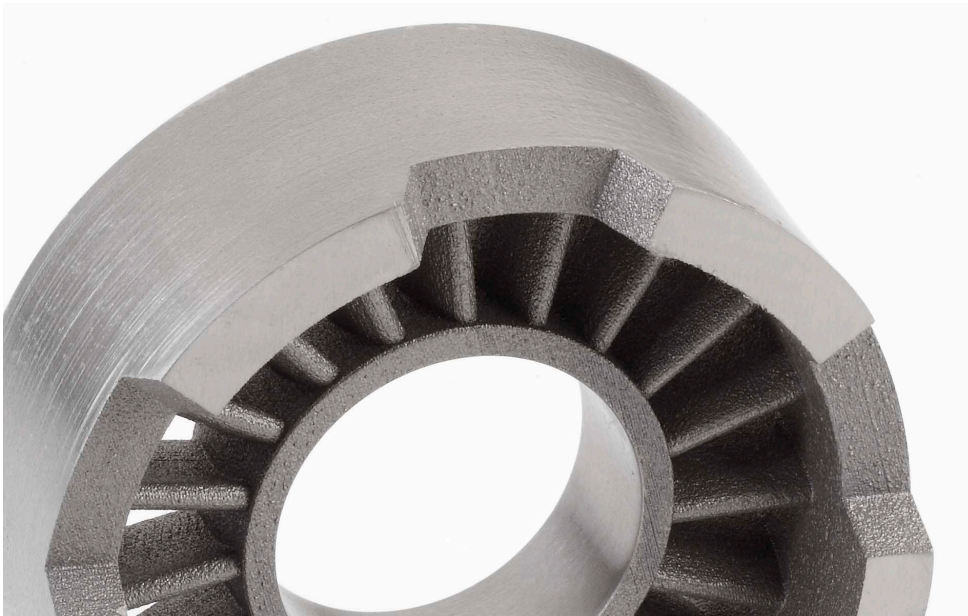

A functional metal part in stainless steel-bronze matrix. Part geometry is less complex than for Powder Bed Fusion as the requirements to save material are less relevant. Image courtesy of ExOne.



Binder Jetting part taken out of the powder. Image courtesy of ExOne.

Metal Technologies Compared

Powder Bed Fusion vs. Binder Jetting

When deciding between Powder Bed Fusion and Binder Jetting the trade off is generally cost vs. dimensional and mechanical properties. Binder Jetting metal parts can be up to 10x cheaper than Powder Bed Fusion. However, the dimensional tolerances, as well as the mechanical properties generally aren't as good.

Also, if the size of a part is outside the scope of Powder Bed Fusion and Additive Manufacturing is the technology of choice, Binder Jetting is generally the only option.

	Powder Bed Fusion	Binder Jetting
Tolerance	+/- 0.004" (0.1mm)	+/- 0.008" (0.2mm)
Maximum Part Size	9" (23cm) x 6" (15cm) x 6" (15cm)	15" (38cm) x 14" (36cm) x 29" (74cm)
Strength / Weakness	<ul style="list-style-type: none"> + Highly accurate + Great mechanical properties - High cost - Limited part size 	<ul style="list-style-type: none"> + Low cost + Very large parts ~ Good mechanical properties - Limited accuracy

CNC vs. Additive Manufacturing

The differences between Powder Bed Fusion and Binder Jetting are less relevant when comparing to CNC machining. For simplicity reasons, the comparison with CNC is done with Additive Manufacturing metal in general.

Generally, a part that can be machined with little effort should generally be machined. It usually only makes sense to apply Additive Manufacturing in cases where five axis milling or multiple clamping positions are required or traditional methods are simply not able to produce the part at all.

CNC machining benefits from the tightest tolerances, a wide variety of available materials and finishing options, and fast turn-around globally. However, if a design has complex geometries, or high value materials are required (less attractive for subtractive methods), one might consider AM as the best solution.

In a bigger context, there are alternative methods of production. If, for example, parts are hard to machine, but volumes are high, then Investment Casting using 3D printed patterns can be a good solution for competitive pricing. For even higher volumes, but simpler geometries, Die Casting is likely the best option. A detailed treatment of both Investment- and Die casting is outside the scope of this document.

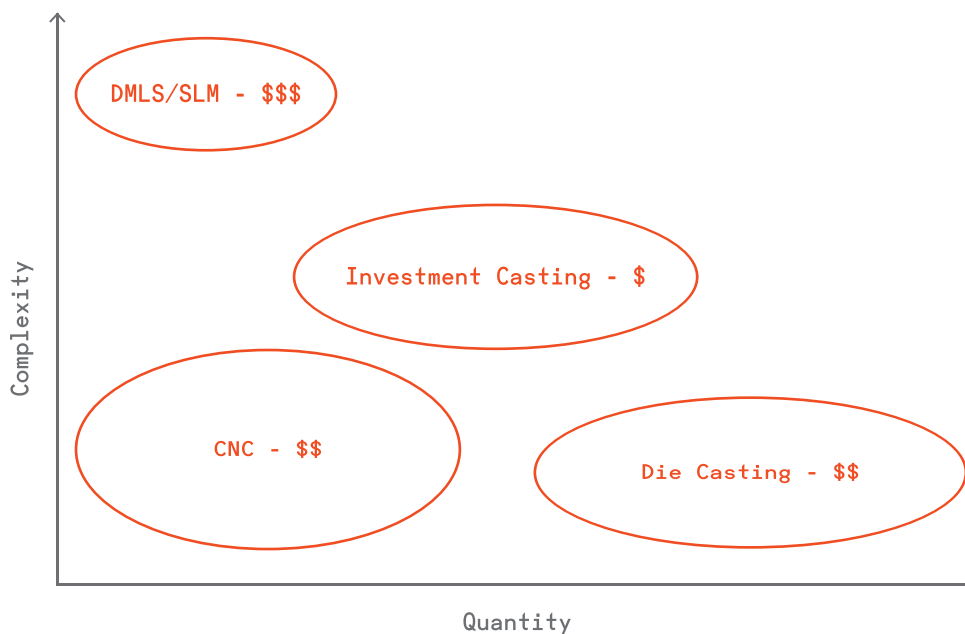

The position of each production method on against volume and complexity of the geometry. The \$ signs are relative indicators of cost per part

How-to get started

3D Hubs offers all 3 metal production technologies discussed in this document through its Managed Services. Additionally, sheet metal fabrication is also offered.

It's easy to get started and request a free quote:

1. Go to the 3D Hubs Managed Services page: 3dhubs.com/managed-services
2. Request a free quote
3. Upload your files and fill in the details of your project

We'll get back in touch with a free quote within 24h after submitting the form.

Still unsure about your design and not ready to go into production? You can [create a low-cost 3D printed plastic prototype](#) and get it printed within 24h.



3D Hubs Resources

Get an instant quote for metal parts

- Online:** Upload your CAD file at 3dhubs.com/managed-services
- Supported File Types:** .step, .stp, .iges, .x_t, .x_b, .sldrpt, .ipt, .3dxml, .prt, .sat, .cgr, .3dm, .catpart, .scad (max file size: 250 MB)
All uploads are secure and confidential
- Capabilities:** Additive manufacturing (3D printing), CNC Machining, Sheet Metal Fabrication, Investment Casting.

About 3D Hubs

3D Hubs is the world's largest network of manufacturing services. Through this network of local service providers, 3D Hubs finds the fastest and most price competitive manufacturing solution near you, making it easy to do custom prototyping and short production runs.

Contact

Email: support@3dhubs.com
Address: Frederiksplein 42,
1017 XN,
Amsterdam